

ITEM NO.	PART NUMBER	DESCRIPTION	QTY.
1	Main Assembly		1
2	Chasis Assembly		1
3	Front Suspension system		1
4	Rear Suspension System		1
5	Part40		1
6	Part41		1
7	Part42		1
8	Part1		1
9	Part28		1
10	Part75		1
11	Part76		1
12	Part77		1
13	6245K48		2
14	sprocket support		1
15	2302K317	Roller Chain Sprocket	2
16	support 2 sprocket		1
17	4182N2	Idler Sprocket for Roller Chain	2
18	Part80		1
19	roll support		1
20	Part81		1
21	Main hub		1
22	6836N155		2

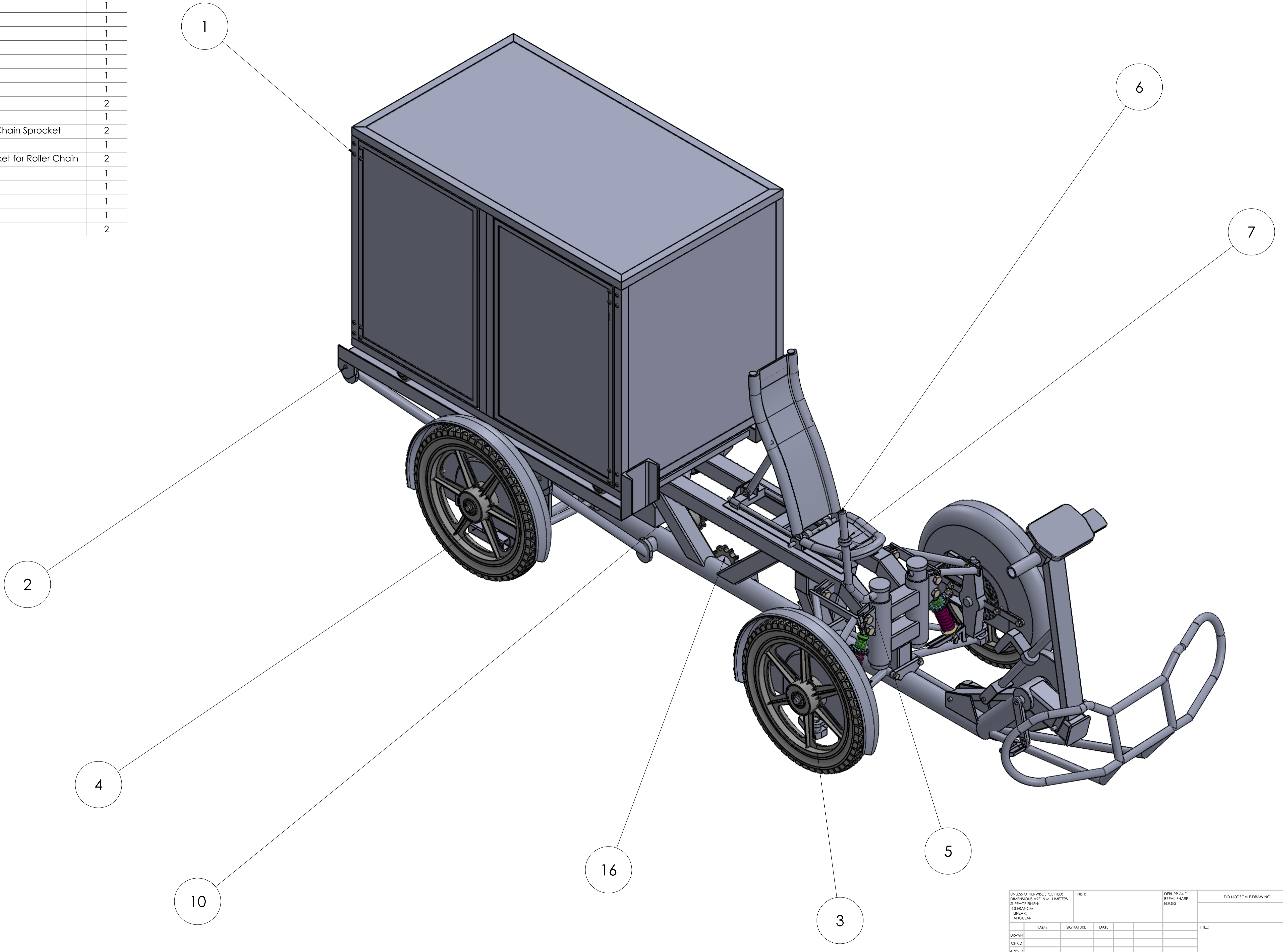

UNLESS OTHERWISE SPECIFIED: DIMENSIONS ARE IN MILLIMETERS				FINISH:	DEBURR AND BREAK SHARP EDGES	DO NOT SCALE DRAWING	REVISION
SURFACE FINISH:							
TOLERANCES:							
LINEAR:							
ANGULAR:							
NAME	SIGNATURE	DATE				TITLE:	
DRAWN:							
CHEK:							
APPVD:							
MFG:							
Q.A.							
				MATERIAL:		DWG NO:	
						Final Assembly	A1
				WEIGHT:		SCALE:1:5	SHEET 1 OF 4

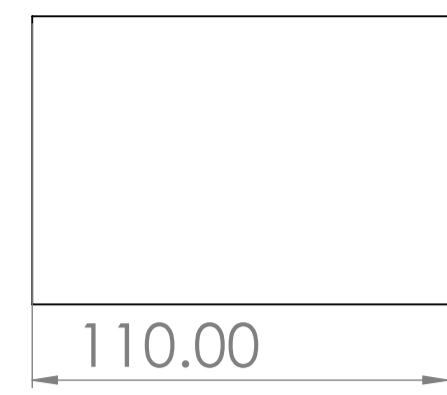
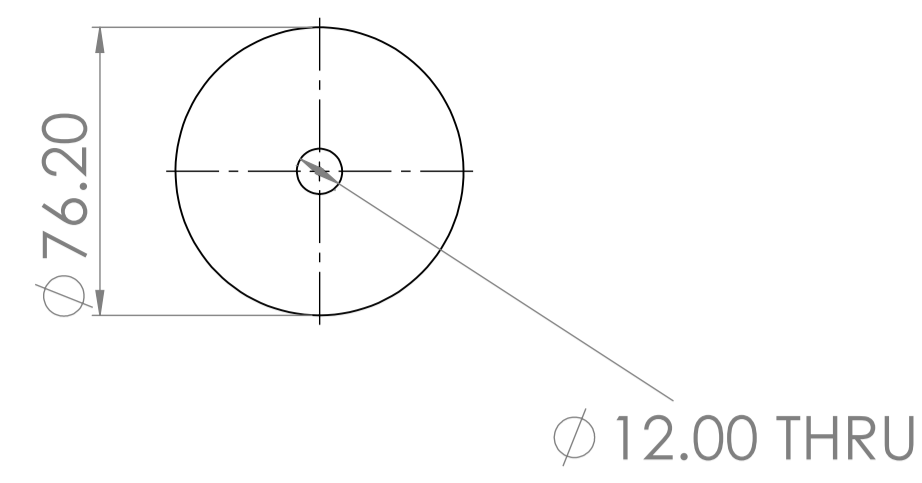

ROLLER DRUM

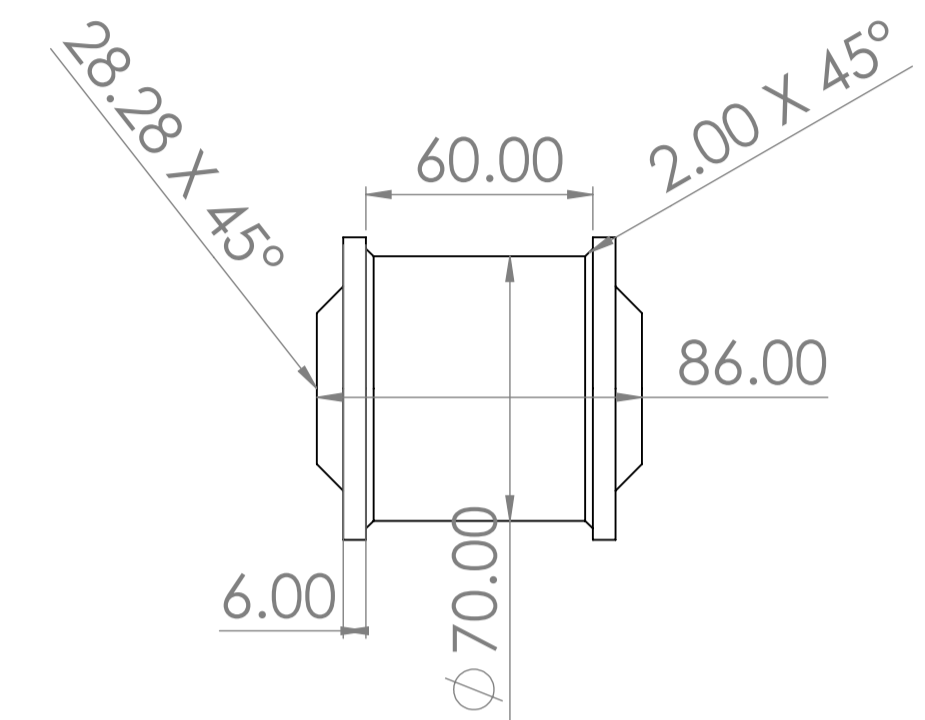
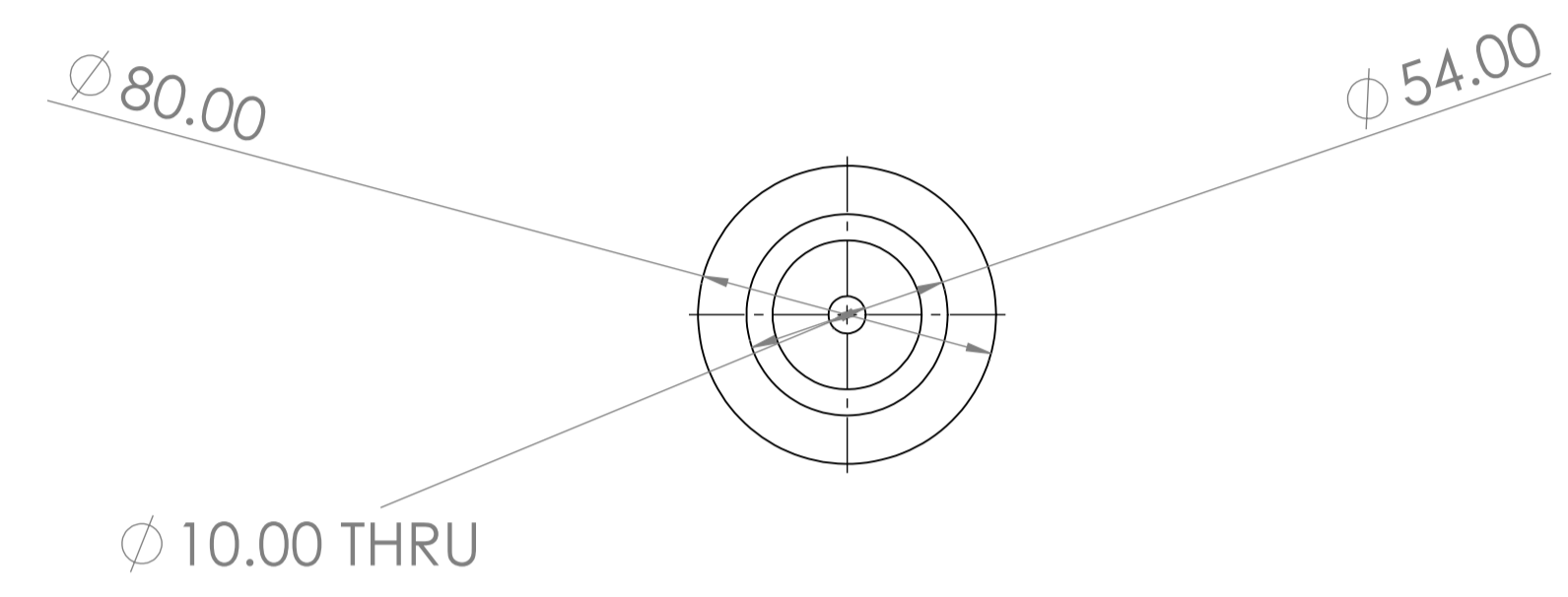
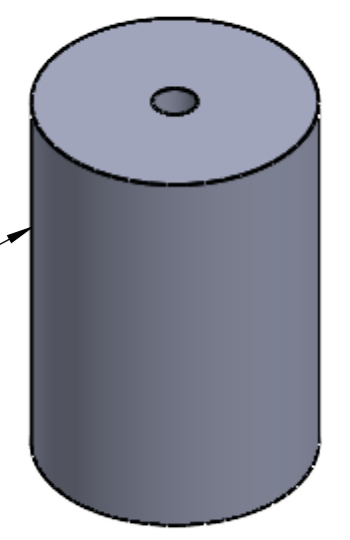

REAR DRUM

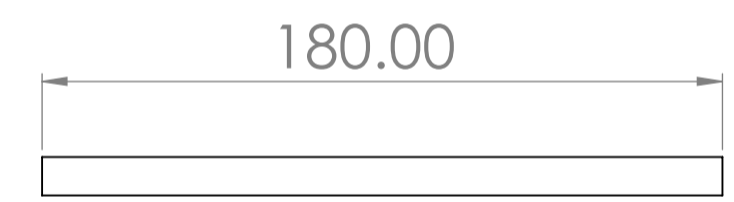
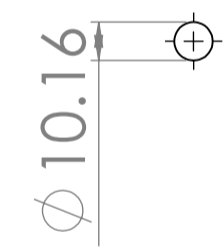
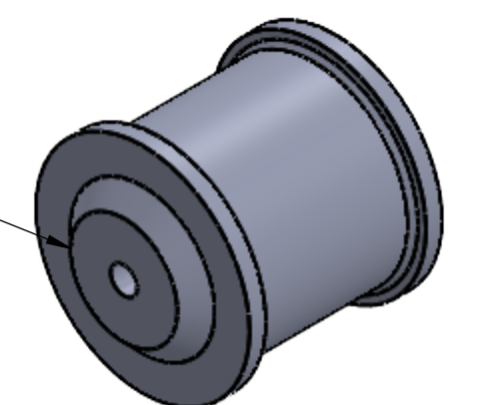

SHAFT

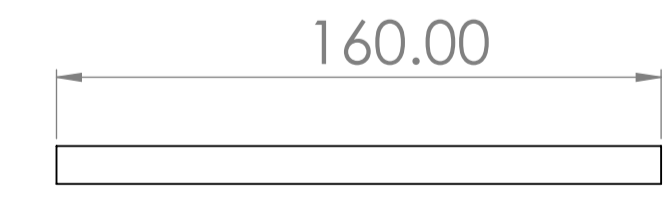
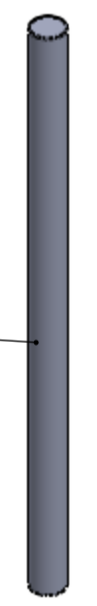

SHAFT REAR HUB

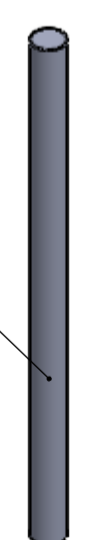

UNLESS OTHERWISE SPECIFIED: DIMENSIONS ARE IN MILLIMETERS		FINISH:	DEBURR AND BREAK SHARP EDGES		DO NOT SCALE DRAWING	REVISION
SURFACE FINISH:						
TOLERANCES:						
LINEAR:						
ANGULAR:						
NAME	SIGNATURE	DATE			TITLE:	
DRAWN						
CHEK						
APPVD						
MFG						
Q.A.						
		MATERIAL:		DWG NO.		parts
		WEIGHT:		SCALE:1:2		A1
				SHEET 2 OF 4		

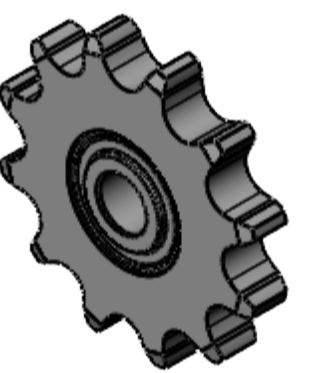
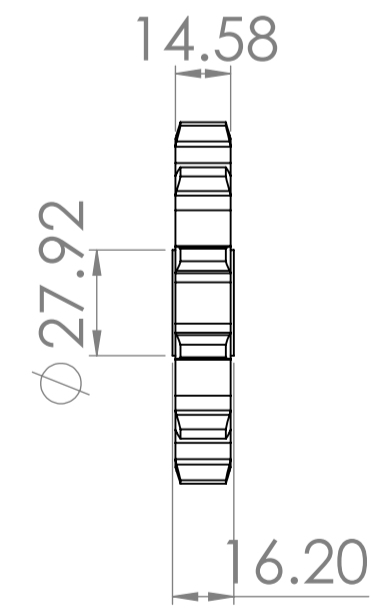
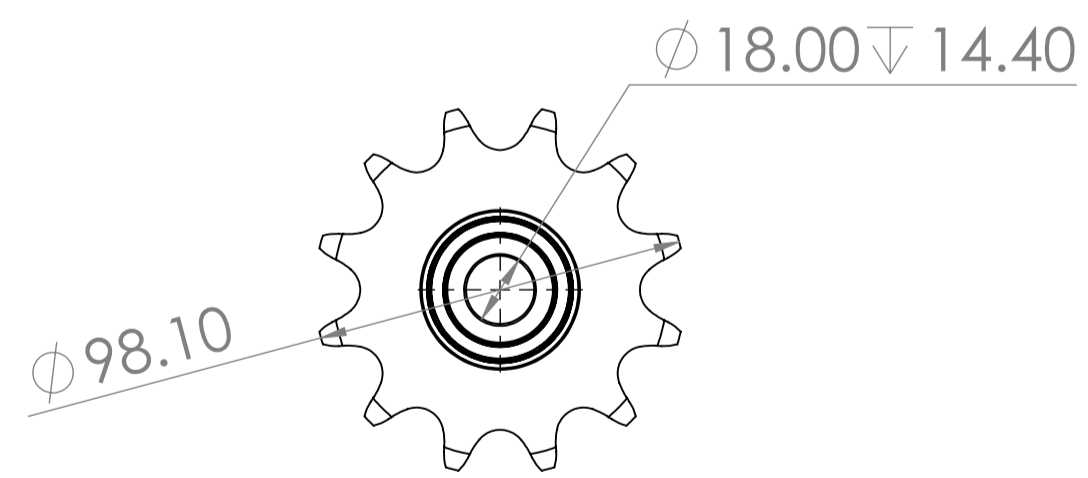
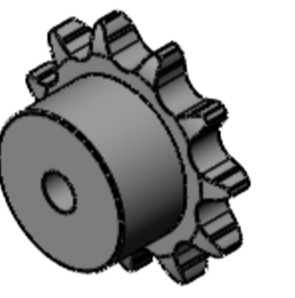
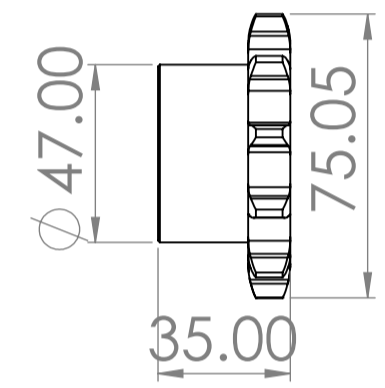
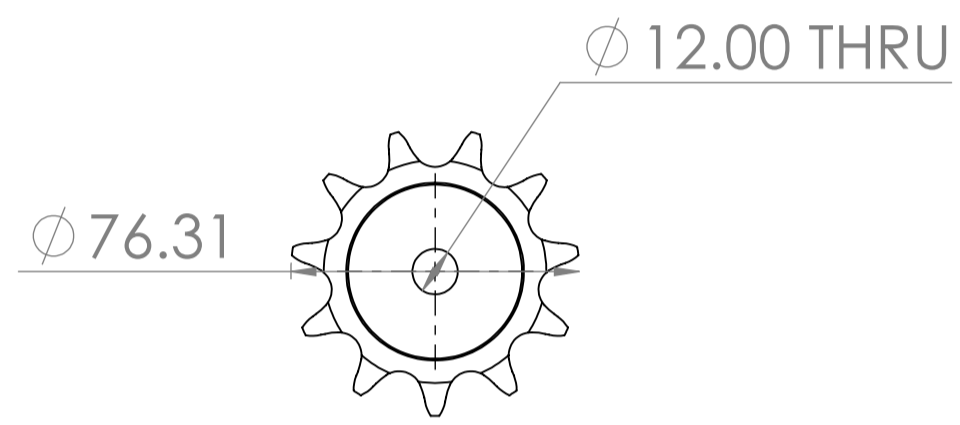
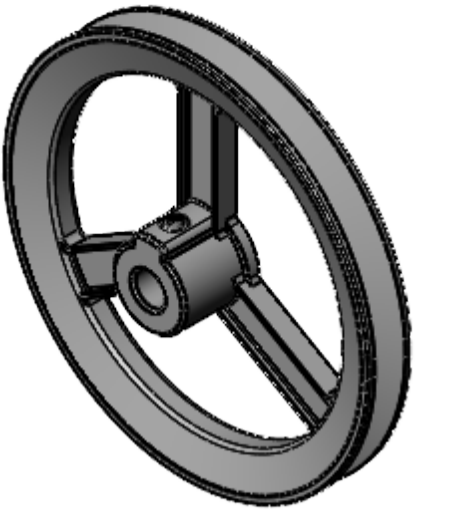
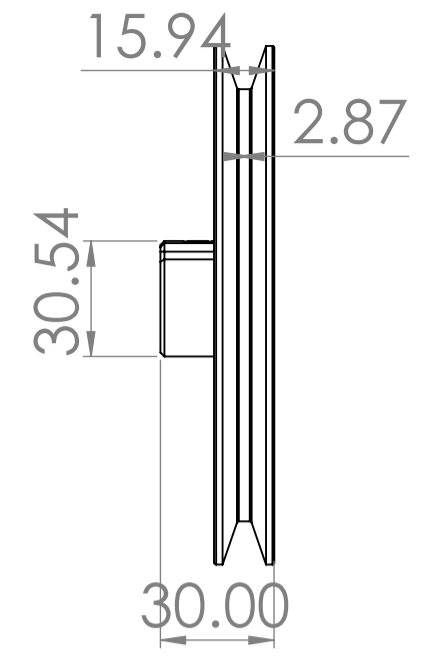
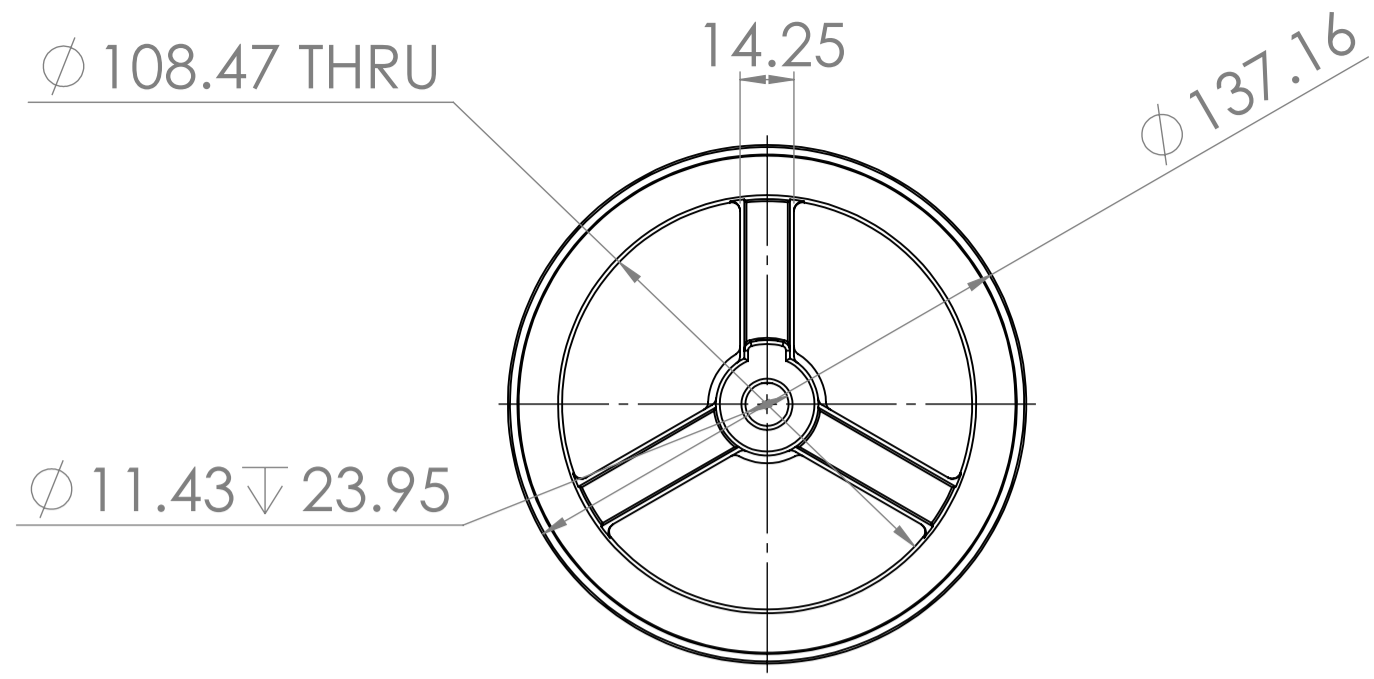

UNLESS OTHERWISE SPECIFIED: DIMENSIONS ARE IN MILLIMETERS		FINISH:	DEBURR AND BREAK SHARP EDGES	DO NOT SCALE DRAWING	REVISION
SURFACE FINISH:					
TOLERANCES:					
LINEAR:					
ANGULAR:					
NAME	SIGNATURE	DATE		TITLE:	
DRAWN					
CHEK					
APPVD					
MFG					
Q.A.			MATERIAL:	DWG NO.	A1
				standard sprockets and pulleys	
			WEIGHT:	SCALE:1:2	SHEET 3 OF 4

ITEM NO.	QTY.	DESCRIPTION	LENGTH
1	1	PIPE, SCH 40, 38.10 DIA.	25

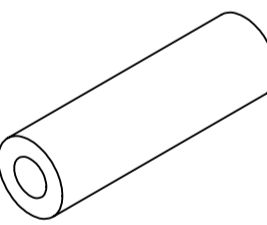
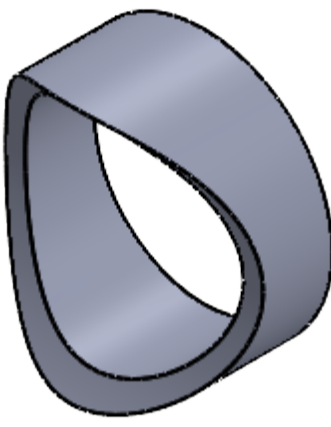
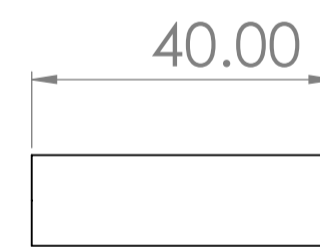
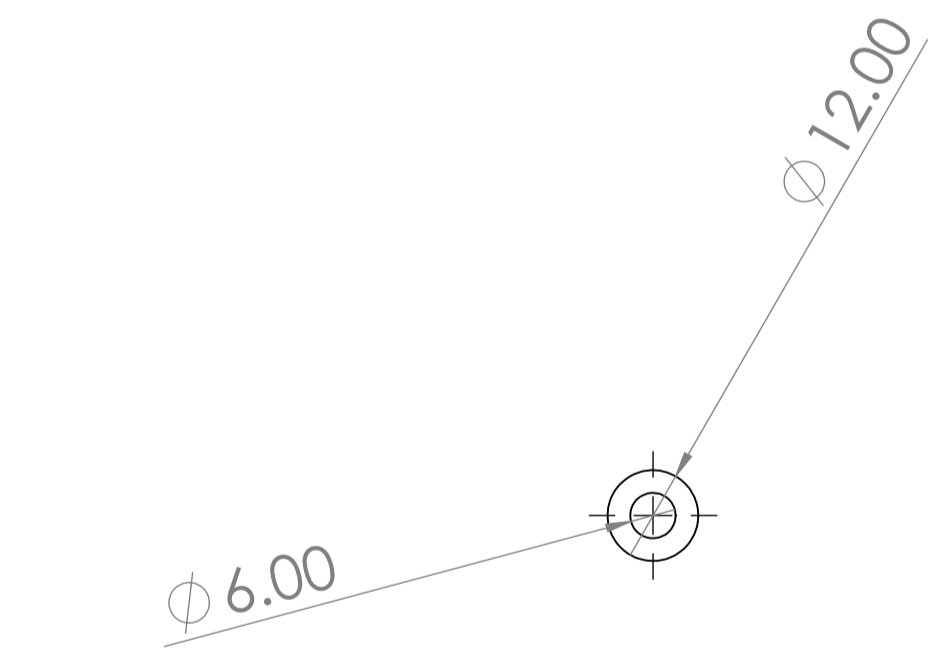
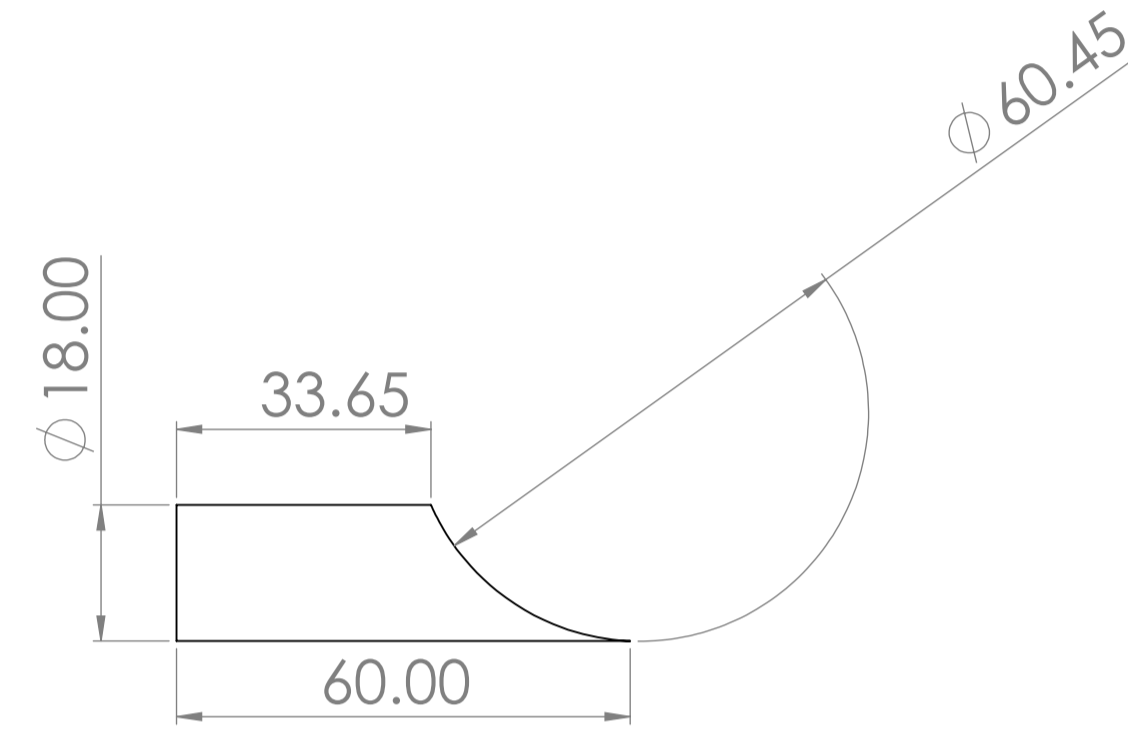
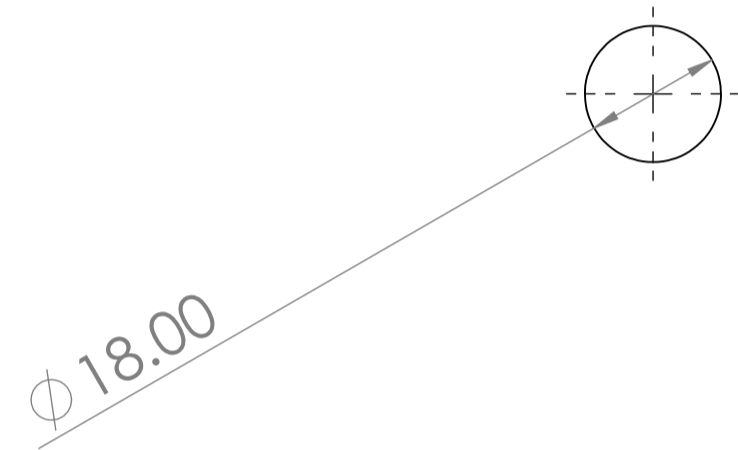
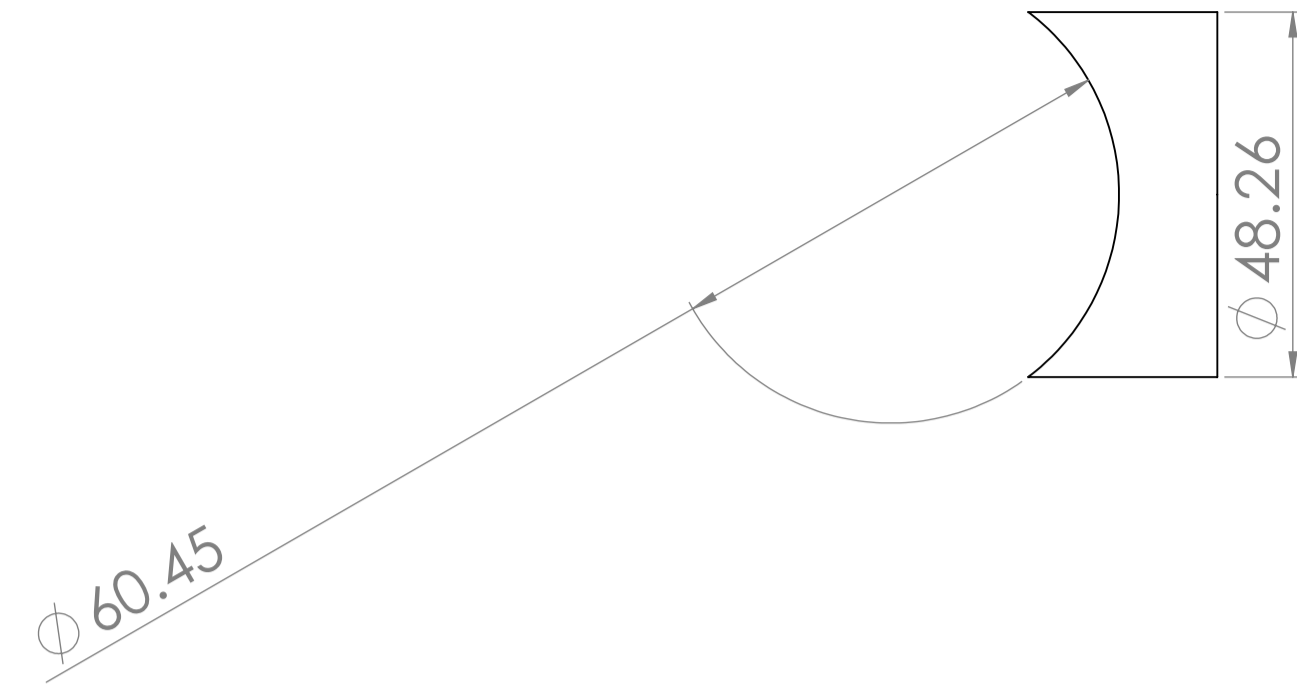
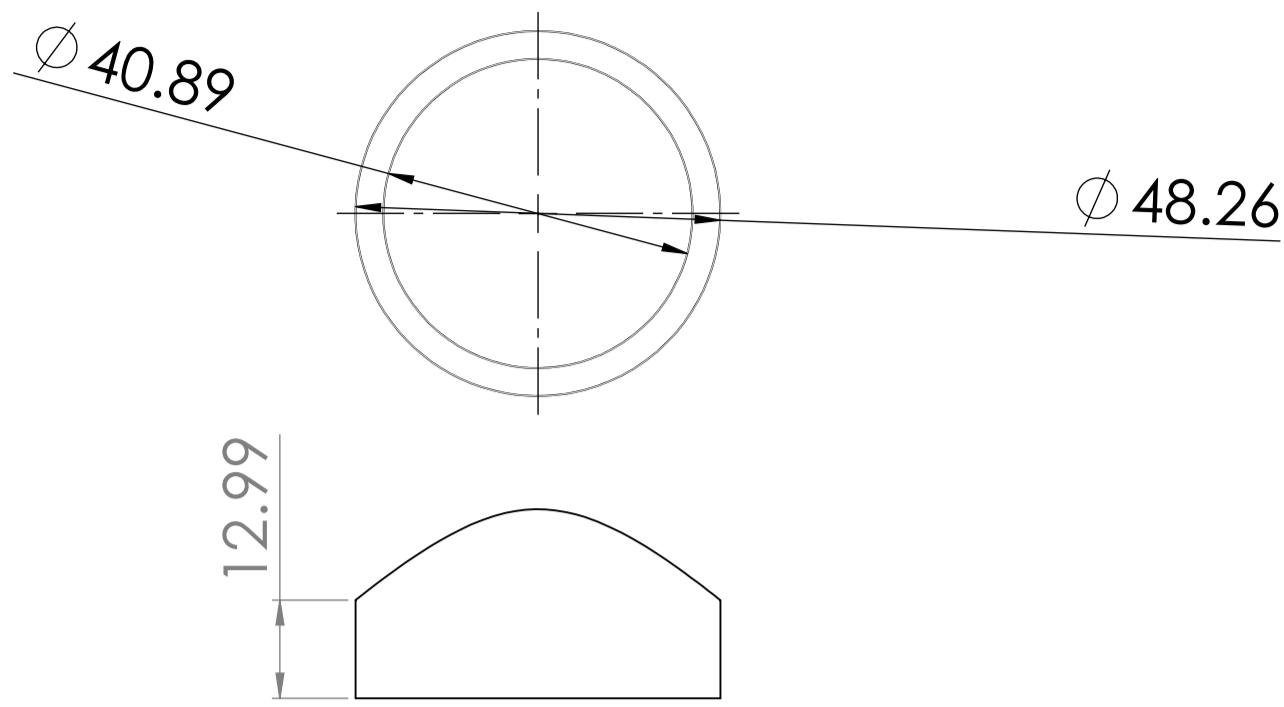

UNLESS OTHERWISE SPECIFIED: DIMENSIONS ARE IN MILLIMETERS		FINISH:	DEBURR AND BREAK SHARP EDGES	DO NOT SCALE DRAWING	REVISION
SURFACE FINISH:					
TOLERANCES:					
LINEAR:					
ANGULAR:					
NAME	SIGNATURE	DATE			TITLE:
DRAWN					
CHECKED					
APPROVED					
MFG					
Q.A.					
			MATERIAL:	DWG NO.	
			WEIGHT:	SCALE:1:1	SHEET 4 OF 4

sprockets supports A1