

ITEM NO.	PART NUMBER	QTY.
1	Chasis Mounting stanchoin	2
2	chasis mounting round shaft	2
3	chasis mounting stanchoin	2
4	Inner chasis Mountings shaft	2
5	central pivot	2
6	Mirrorsupport roller	2
7	central pivot roller	4
8	upper chasis cross member	2
9	upper chasis cross member	2
10	Mounting tabs	10
11	Upper control arm	2
12	Chasis pivot bracket	4
13	29635T31_Spoked Hollow-Tread Flat-Free Wheel	2
14	wheel shaft	2
15	Steering knuckle	2
16	brake disk 140mm final	2
17	Pivot block	2
18	Upper pivot plate support	2
19	control arm link	1
20	control arm link 2	1
21	steering knuckle support	2
22	Outer Tie-Rod Bracket	2
23	Lower A-Arm Rear Member	2
24	lower shock mounting bracket	4
25	shock absorption 3D design assembly	2
26	wheel cover plate	2
27	caliper torque arm	4
28	calliper torque arm 2	4
29	caliper torque arm 3	4
30	Bracket for lower linkage connection	2
31	Bracket 2 for lower connection 2	2
32	Lower hinge	2
33	HHBOLT 0.5000-13x1.5x1-N	6
34	Regular FW 0.06	4
35	HBOLT 0.3750-24x1x1-N	4
36	HBOLT 0.3750-24x3.25x1-N	4
37	HBOLT 0.3125-24x1x0.875-N	2
38	HBOLT 0.3750-24x2.25x1-N	2
39	HBOLT 0.3750-24x0.75x0.75-N	10
40	HHJNUT 0.4375-14-D-N	2
41	HHJNUT 0.3750-24-D-N	16
42	Disk caliper	2
43	Disk calliper	2
44	Part62	2
45	Brake holder	2
46	MirrorPart20^Front Suspension system	1
47	MirrorPart21	1

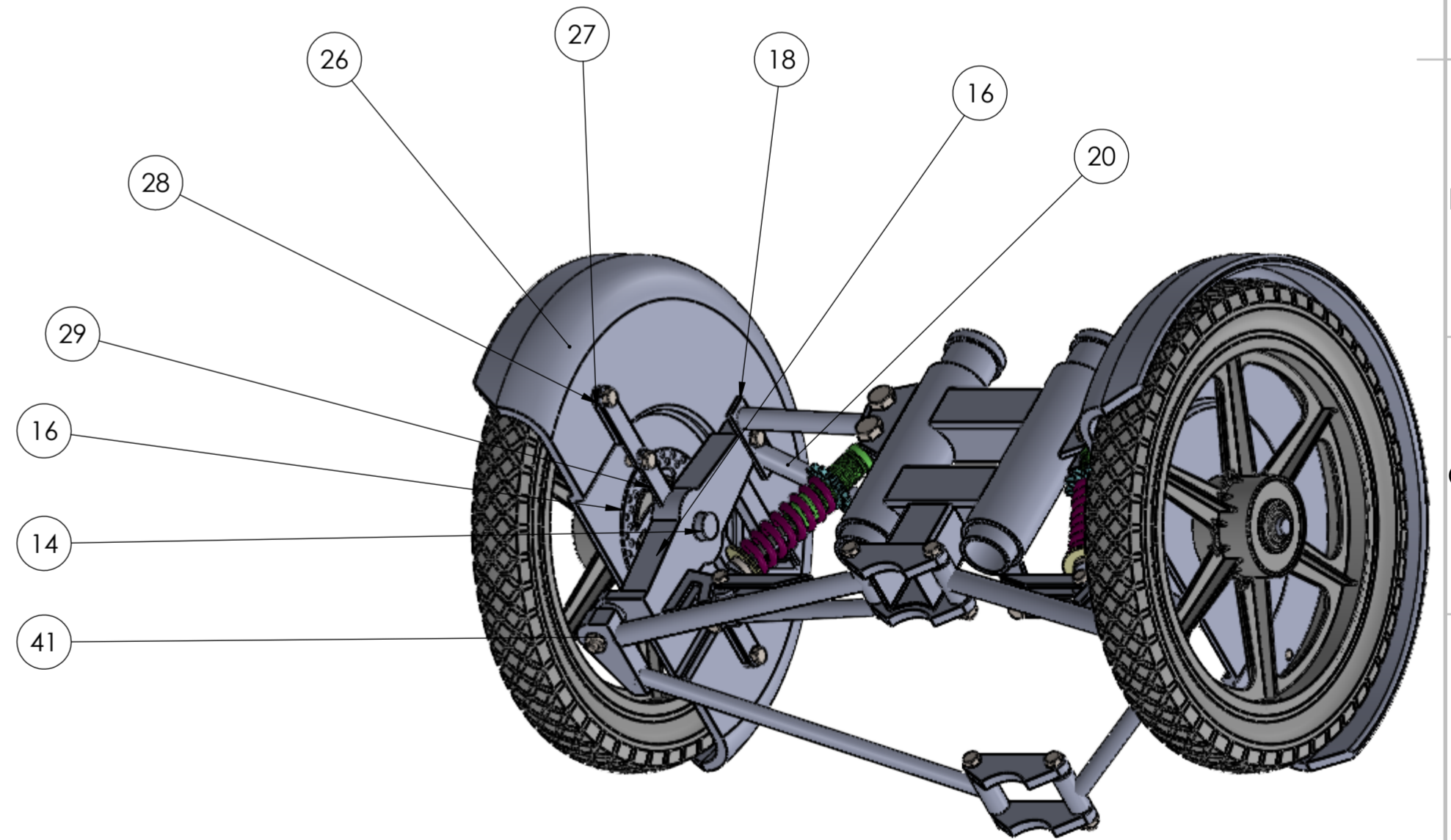

UNLESS OTHERWISE SPECIFIED: DIMENSIONS ARE IN MILLIMETERS			FINISH:		DEBURR AND BREAK SHARP EDGES		DO NOT SCALE DRAWING		REVISION	
SURFACE FINISH:										
TOLERANCES:										
LINEAR:										
ANGULAR:										
DRAWN			NAME		SIGNATURE		DATE		TITLE:	
CHK'D									Front Suspension system Assembly BOM	
APPV'D									DWG. NO.	
MFG									A2	
Q.A							MATERIAL:		SCALE:1:5	
							WEIGHT:		SHEET 1 OF 13	

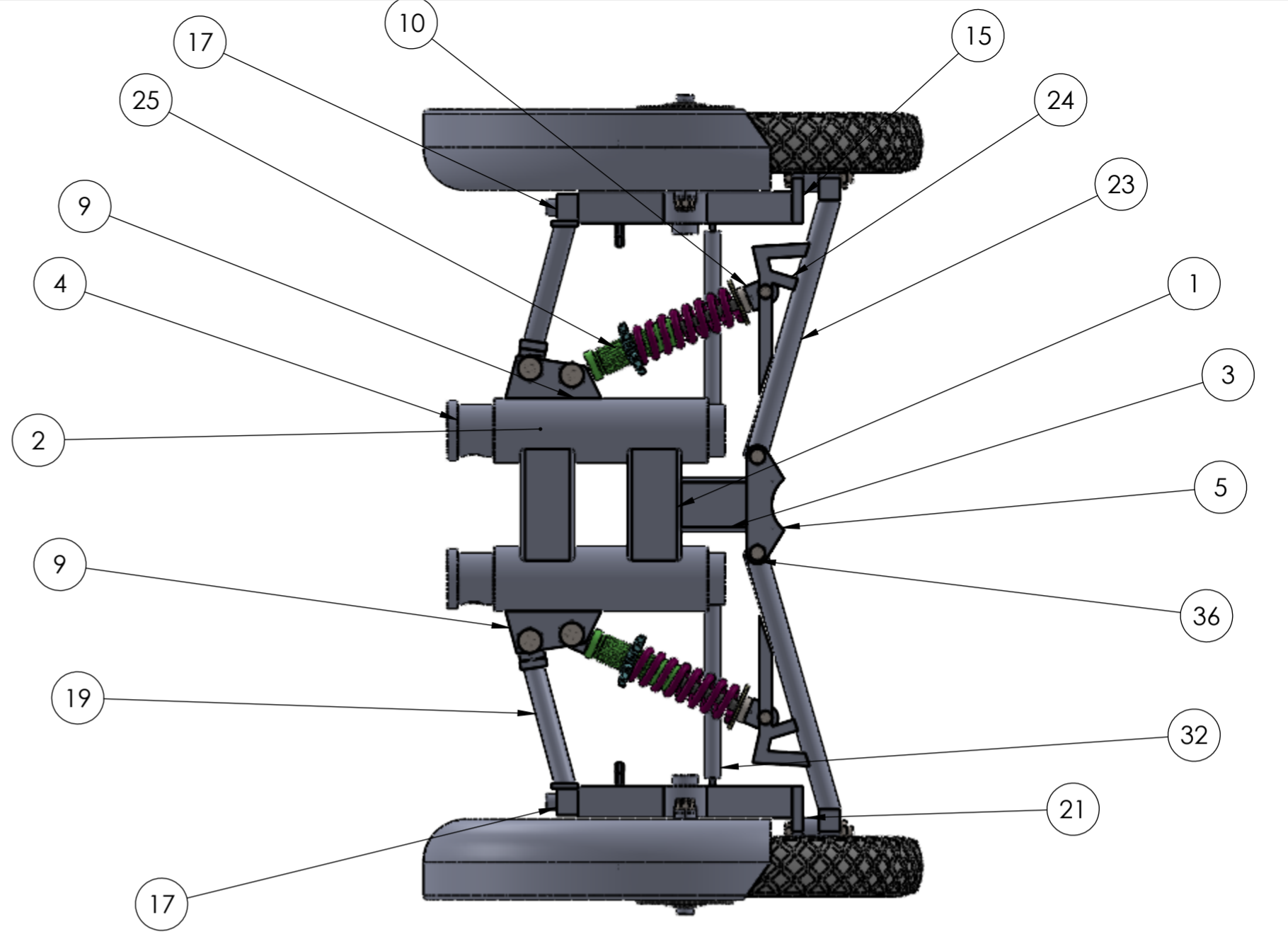
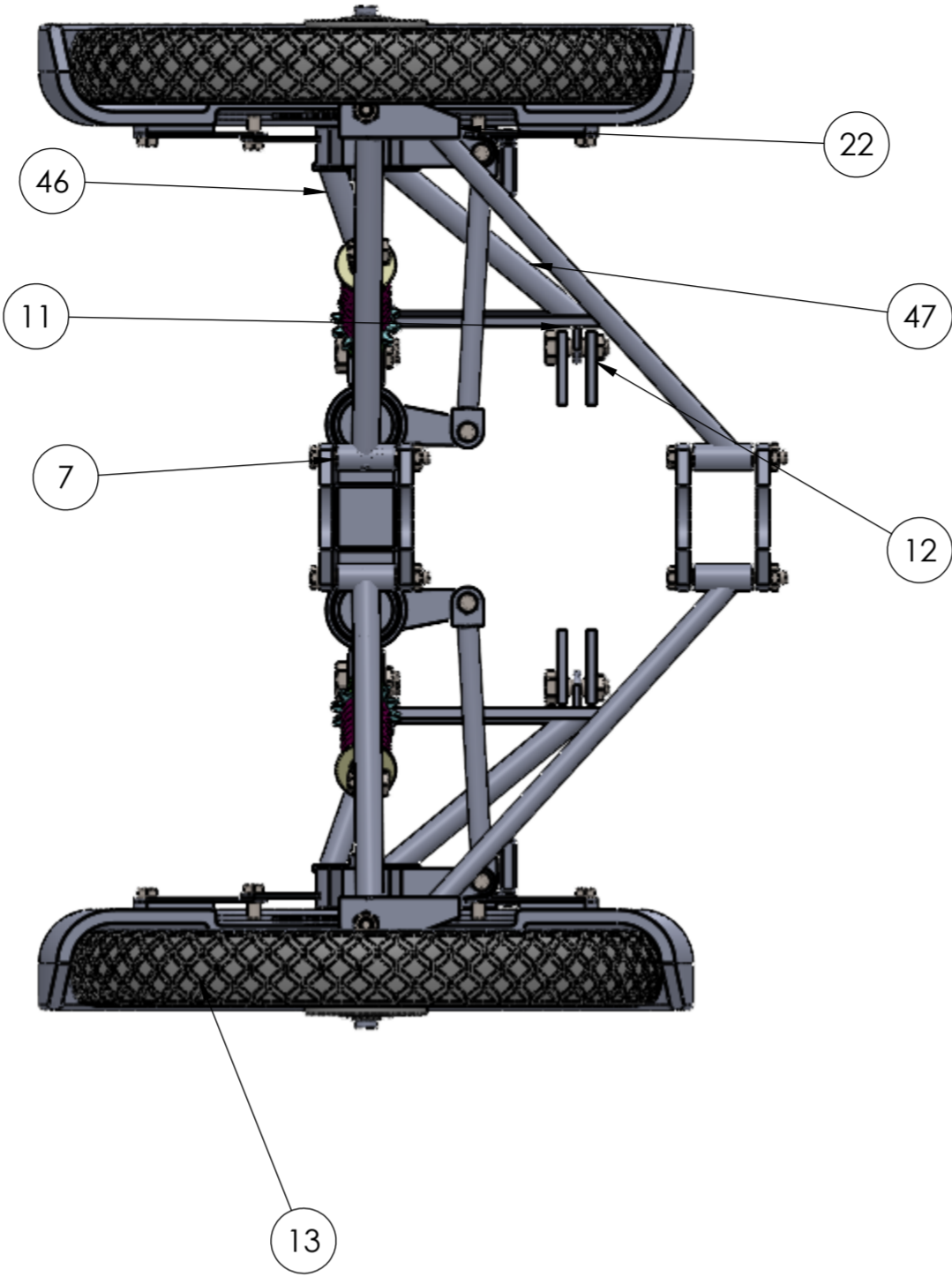
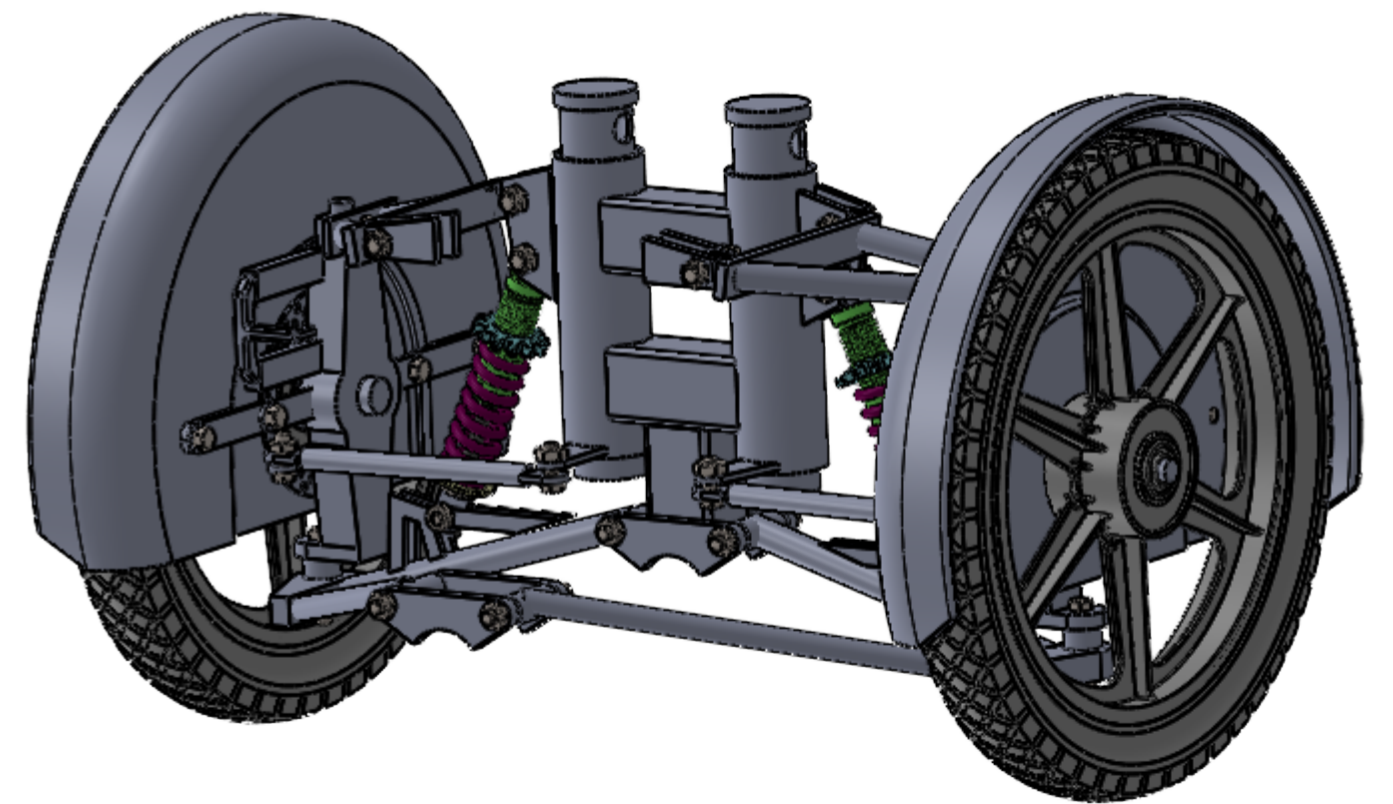
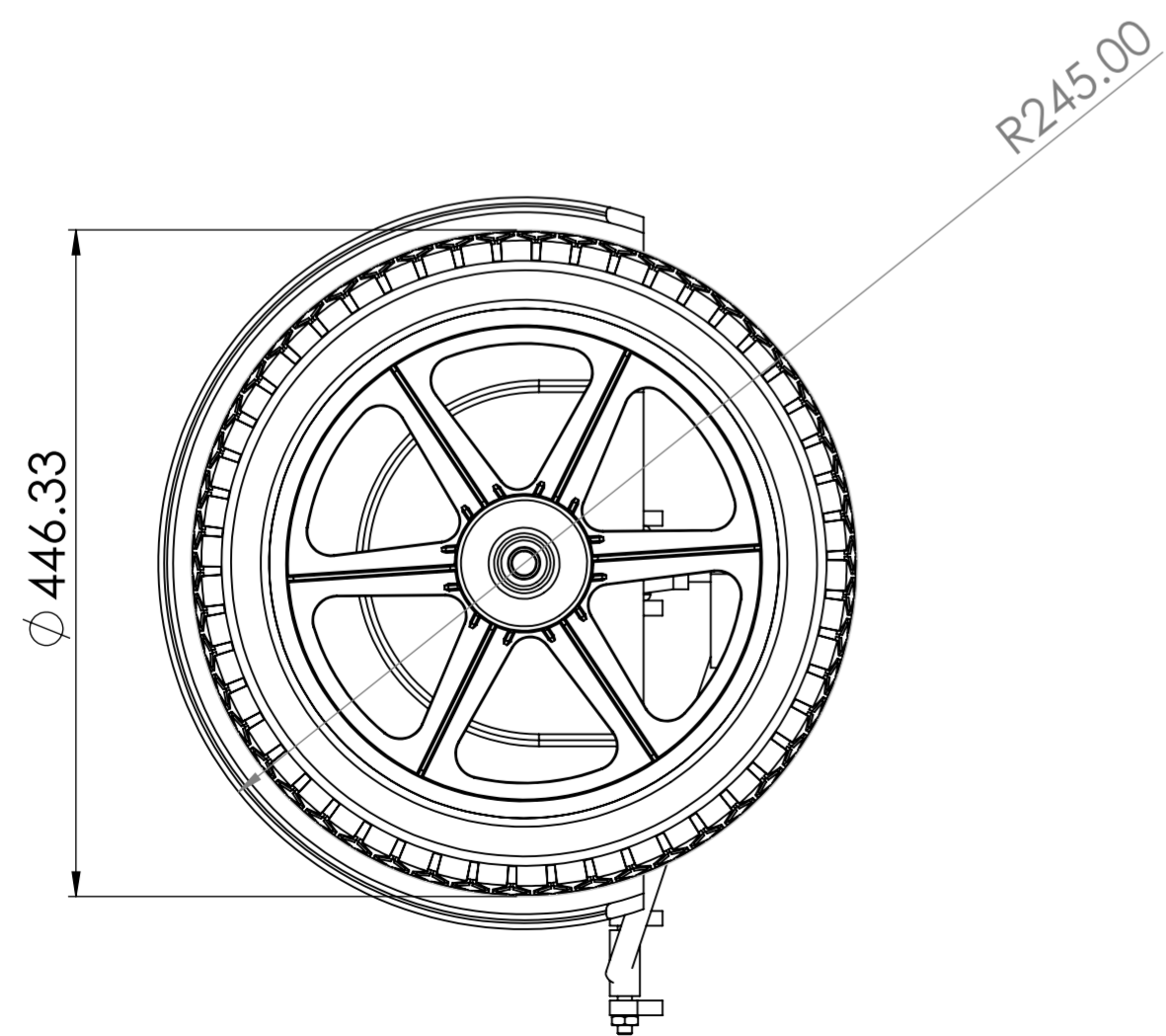
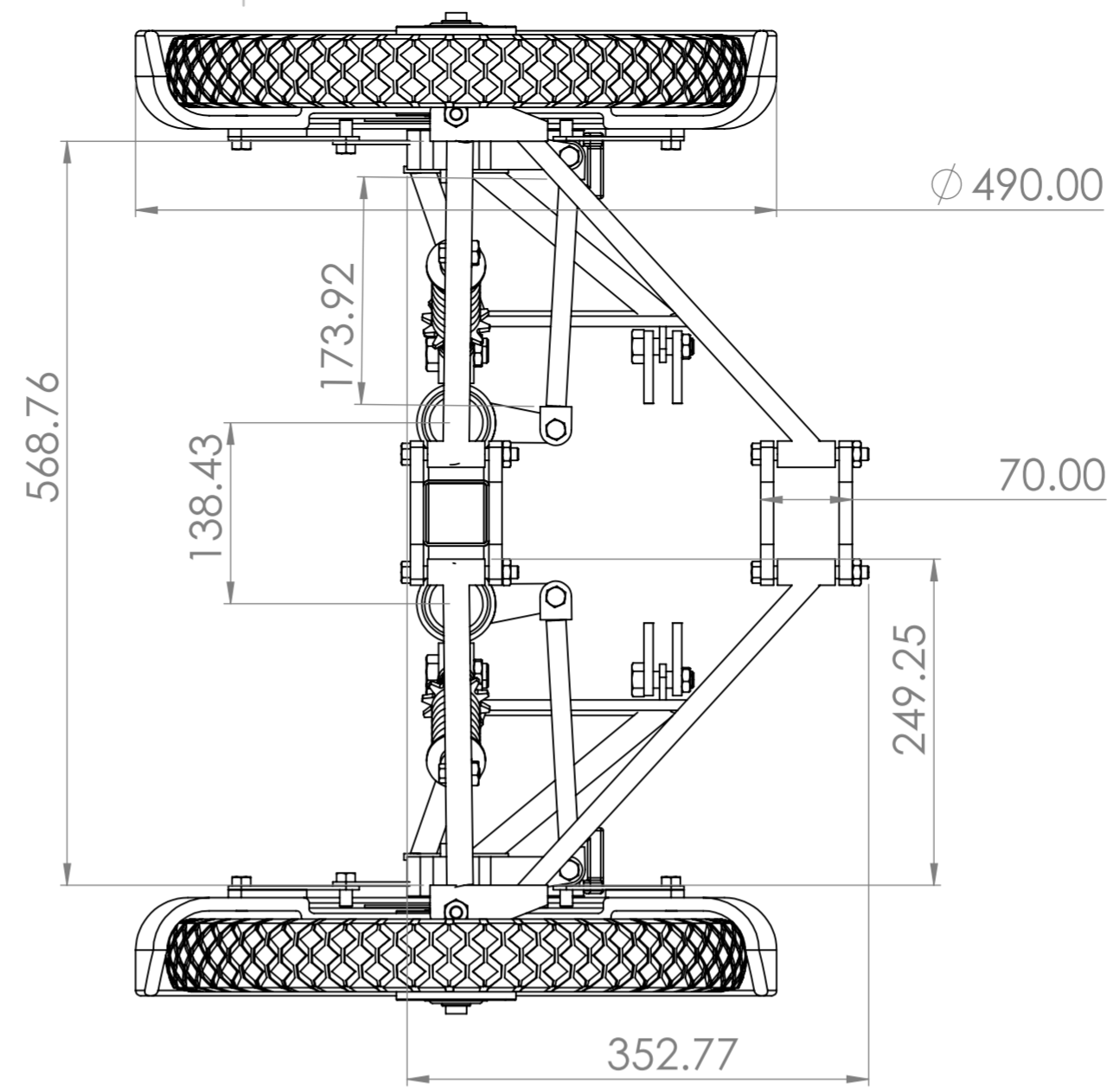
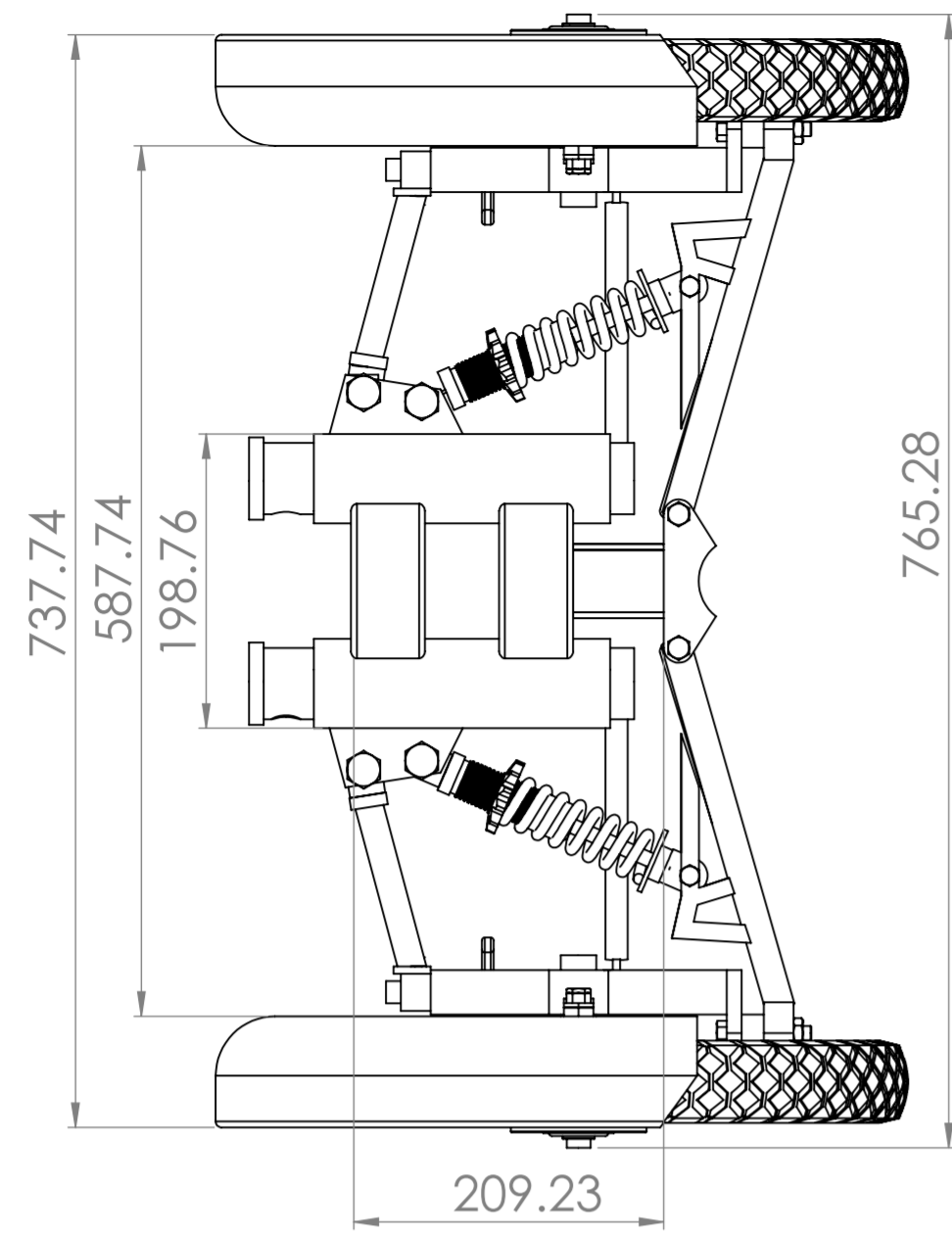

UNLESS OTHERWISE SPECIFIED: DIMENSIONS ARE IN MILLIMETERS			FINISH:		DEBURR AND BREAK SHARP EDGES		DO NOT SCALE DRAWING		REVISION	
SURFACE FINISH:										
TOLERANCES:										
LINEAR:										
ANGULAR:										
DRAWN			NAME	SIGNATURE	DATE			TITLE:		
CHK'D										
APPV'D										
MFG										
Q.A						MATERIAL:		DWG NO.		A2
						WEIGHT:		SCALE:1:5		SHEET 2 OF 13
								Assembly Drawing		

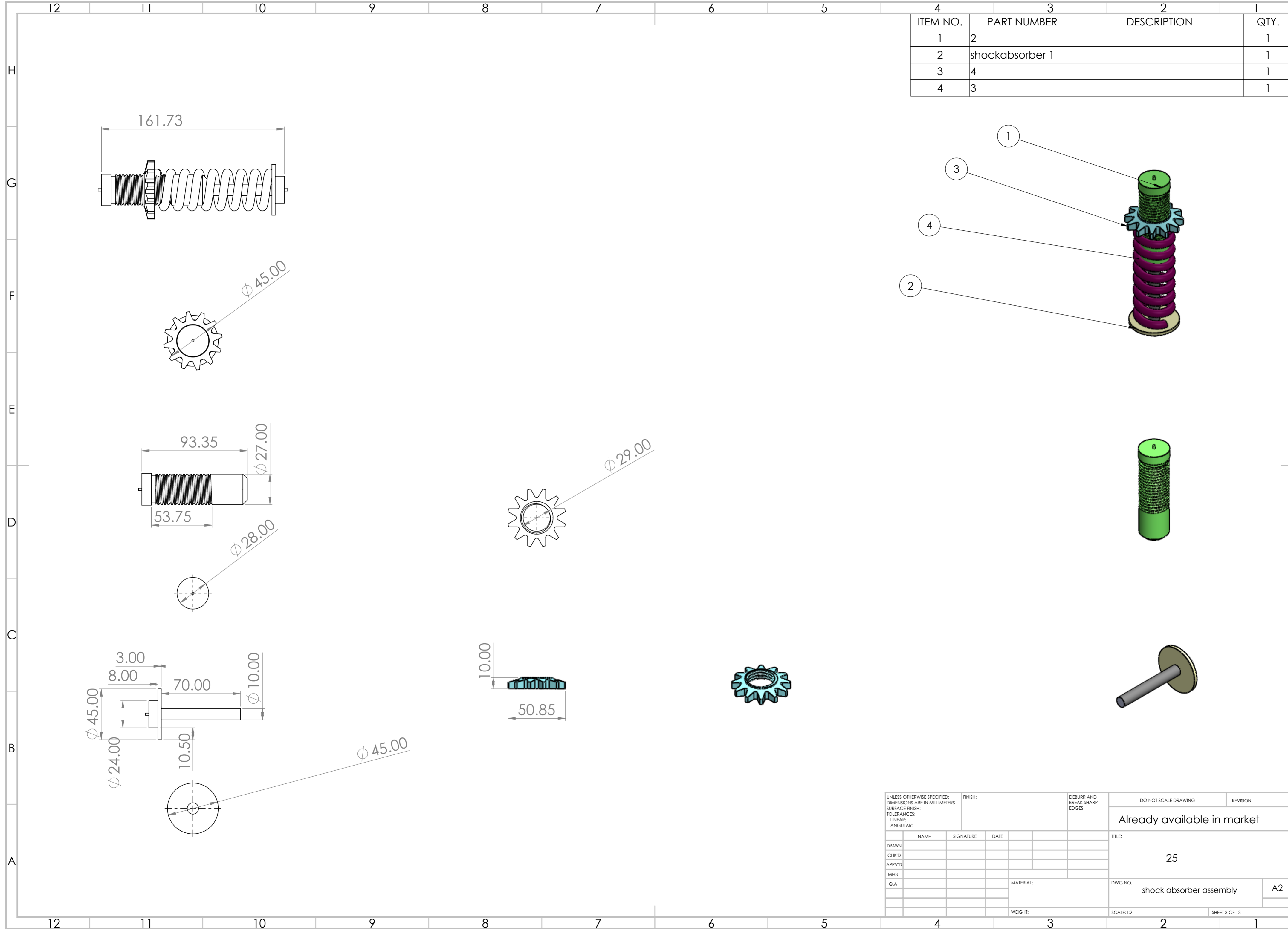

ITEM NO.	PART NUMBER	DESCRIPTION	QTY.
1	2		1
2	shockabsorber 1		1
3	4		1
4	3		1

UNLESS OTHERWISE SPECIFIED: DIMENSIONS ARE IN MILLIMETERS				FINISH:		DEBURR AND BREAK SHARP EDGES		DO NOT SCALE DRAWING		REVISION	
SURFACE FINISH:								Already available in market			
TOLERANCES:								TITLE:			
LINEAR:								25			
ANGULAR:								DWG NO. shock absorber assembly A2			
DRAWN		NAME		SIGNATURE		DATE		MATERIAL:		SCALE:1:2	
CHK'D								WEIGHT:		SHEET 3 OF 13	
APPV'D											
MFG											
Q.A											



12	11	10	9
ITEM NO.	PART NUMBER	DESCRIPTION	QTY.
1	Inner chasis Mountings shaft		1
		PIPE 1.5 SCH 40	1
			1

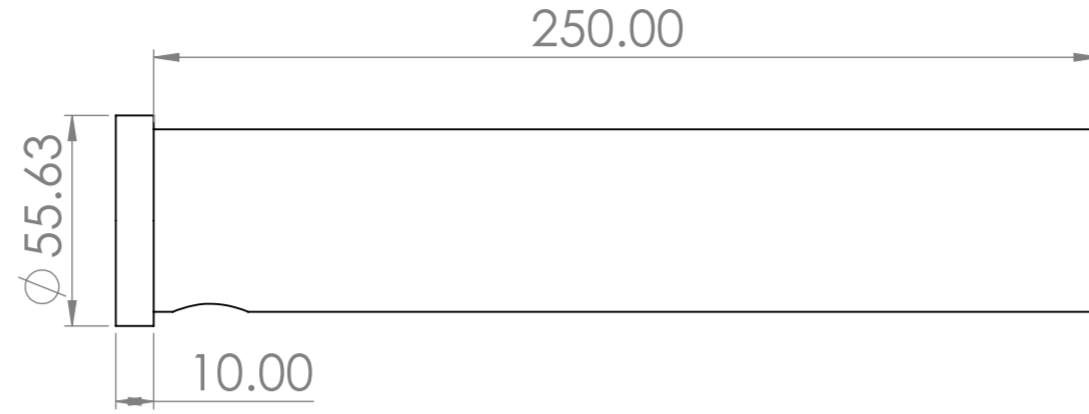
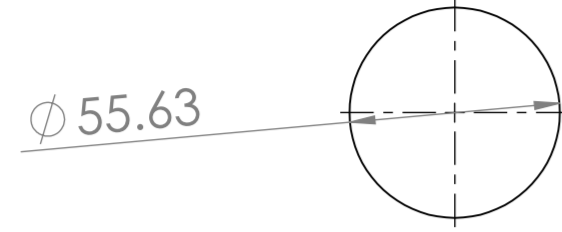

Ø 20.00 THRU

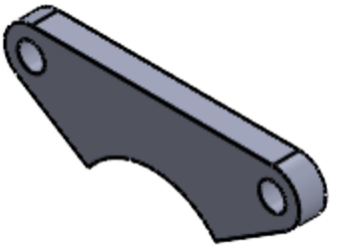
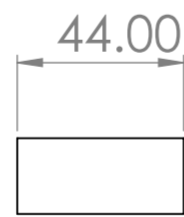
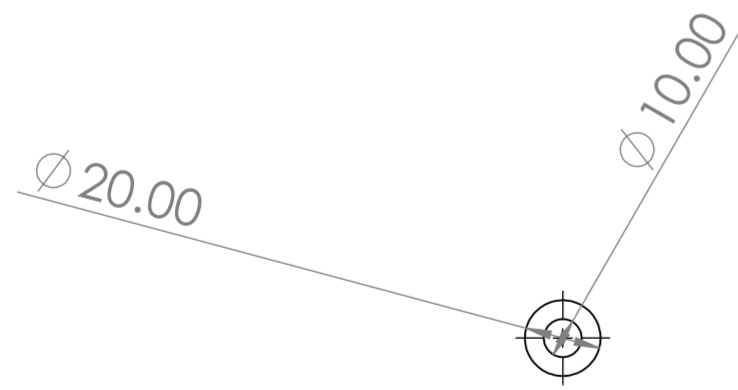
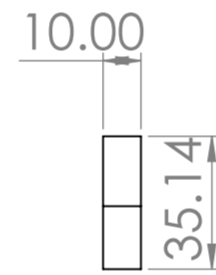
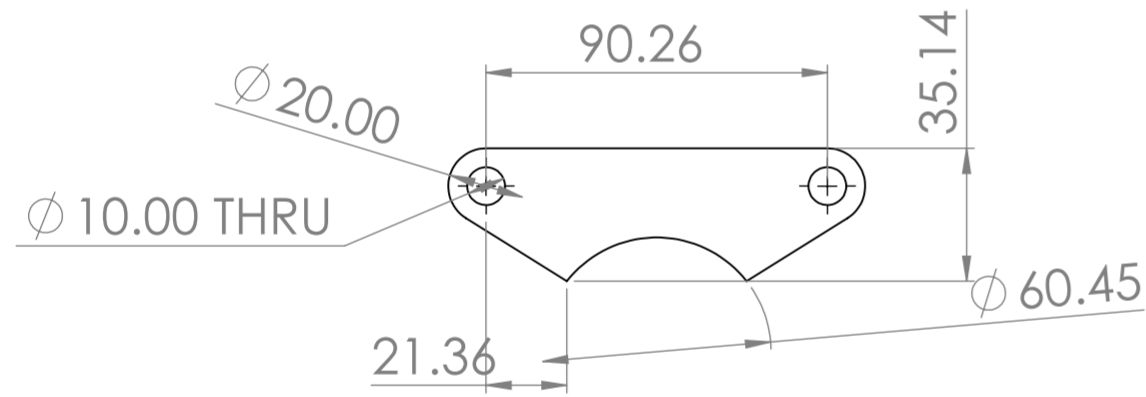
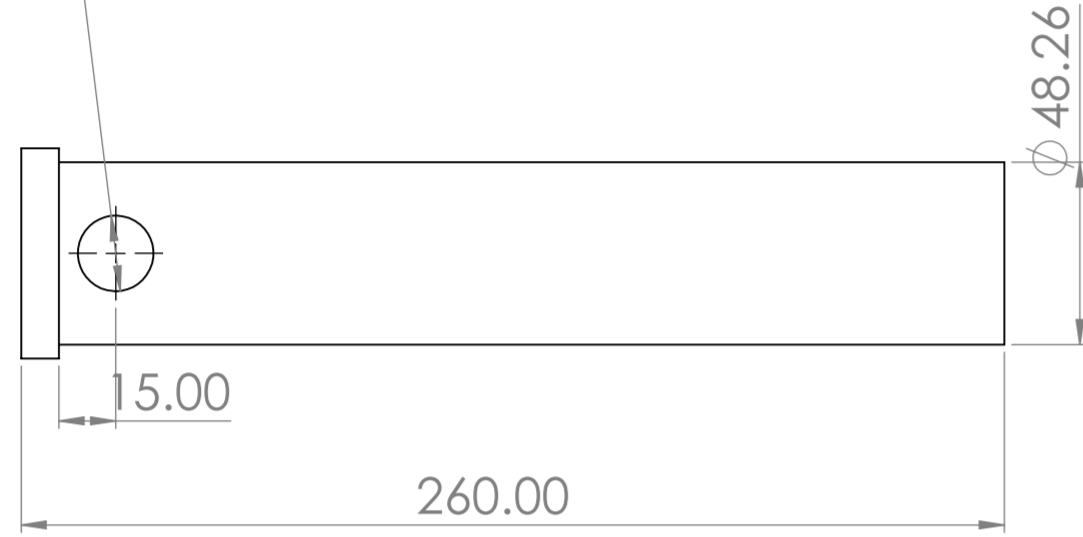

UNLESS OTHERWISE SPECIFIED: DIMENSIONS ARE IN MILLIMETERS				FINISH:		DEBURR AND BREAK SHARP EDGES		DO NOT SCALE DRAWING		REVISION	
SURFACE FINISH:				TOLERANCES:		LINEAR:		ANGULAR:		TITLE:	
DRAWN				NAME		SIGNATURE		DATE		4,5,6	
CHK'D											
APPV'D											
MFG											
Q.A										DWG NO.	
										inner chasis shaft,central pivot central support roller	
										A2	
										SCALE:1:2	
										SHEET 5 OF 13	



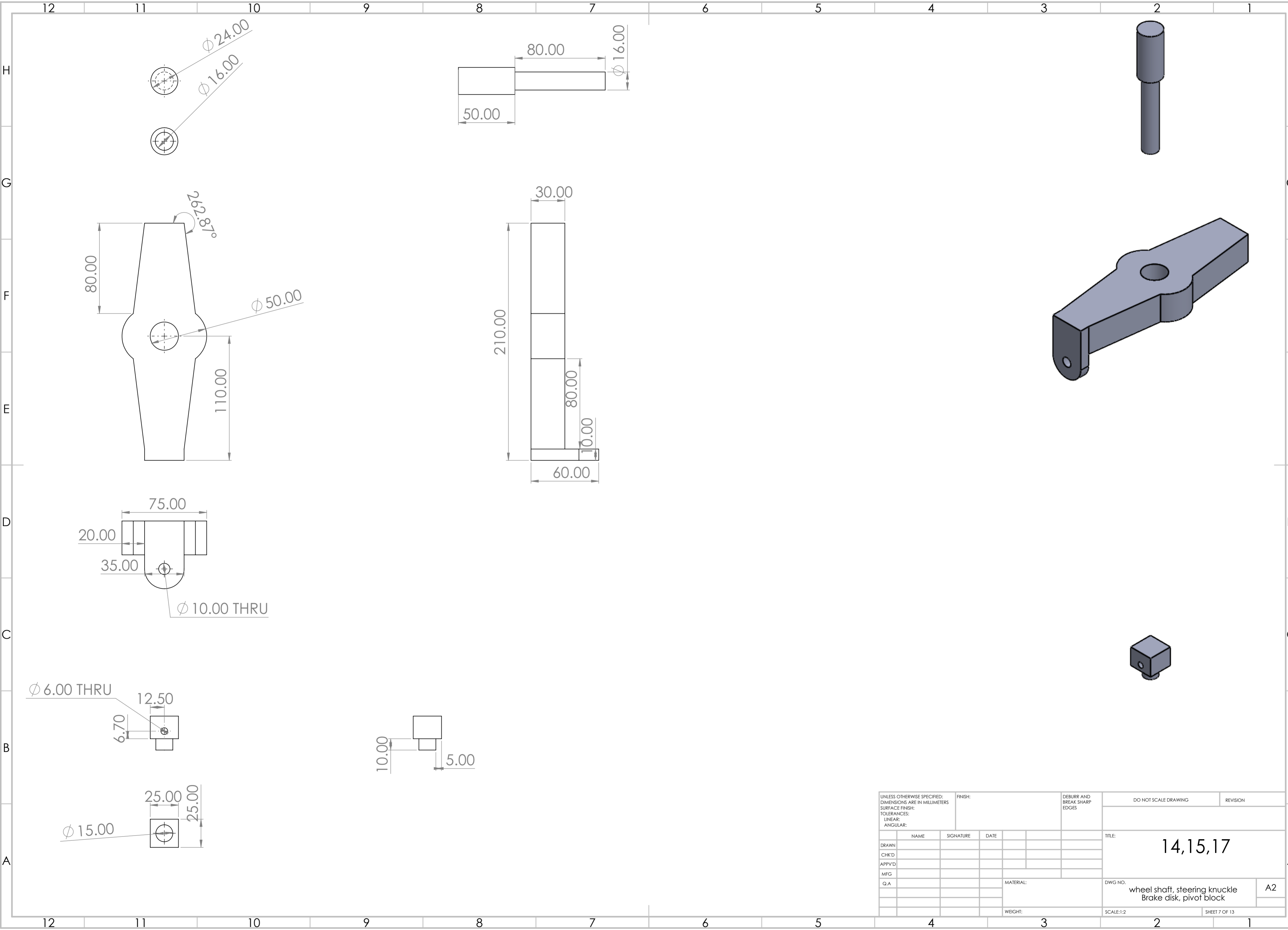

UNLESS OTHERWISE SPECIFIED: DIMENSIONS ARE IN MILLIMETERS				FINISH:		DEBURR AND BREAK SHARP EDGES		DO NOT SCALE DRAWING		REVISION	
SURFACE FINISH:											
TOLERANCES:											
LINEAR:											
ANGULAR:											
	NAME	SIGNATURE	DATE					TITLE: <b>14,15,17</b>			
DRAWN											
CHK'D											
APPV'D											
MFG											
Q.A											
								MATERIAL:		DWG NO. wheel shaft, steering knuckle Brake disk, pivot block	
								WEIGHT:		SCALE:1:2	
										SHEET 7 OF 13	
										A2	

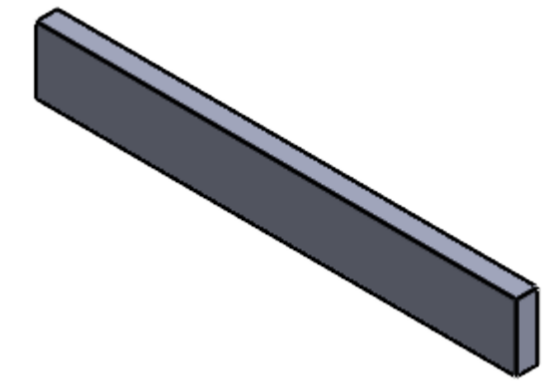
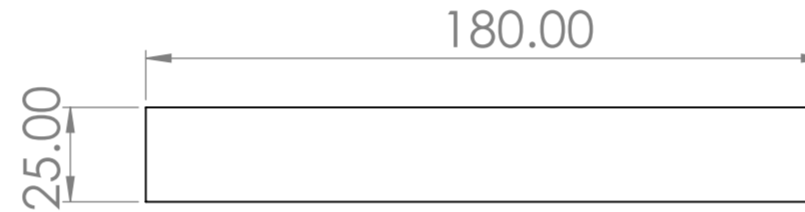
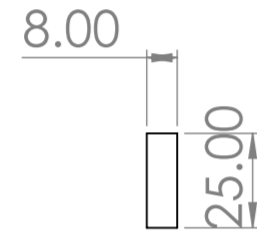
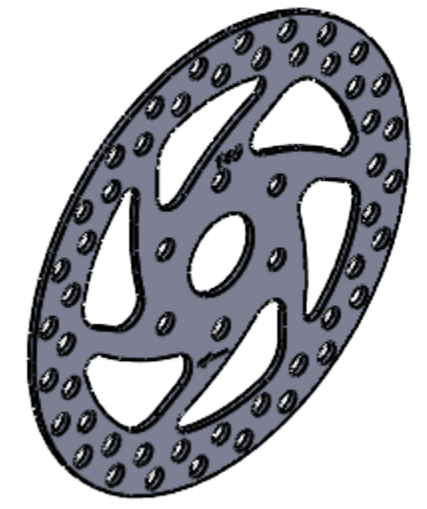
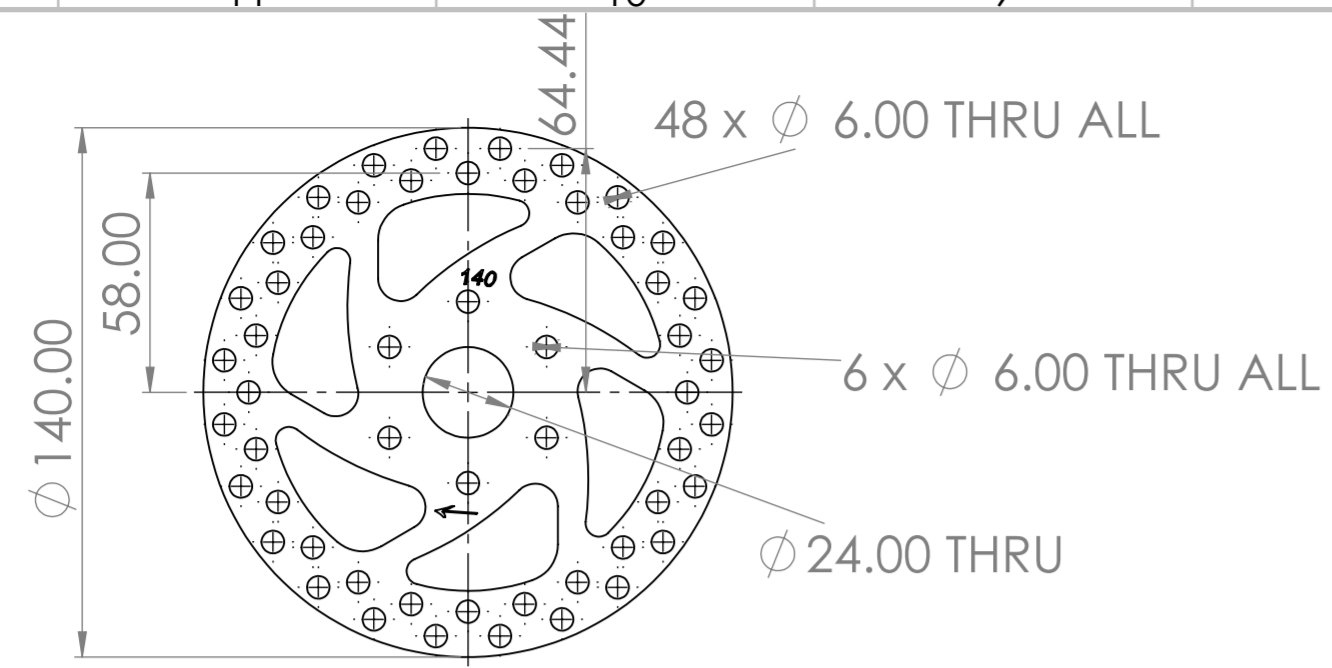

ITEM NO.	QTY.	DESCRIPTION	LENGTH
1	1	PIPE, SCH 40, 12.70 DIA.	195.37

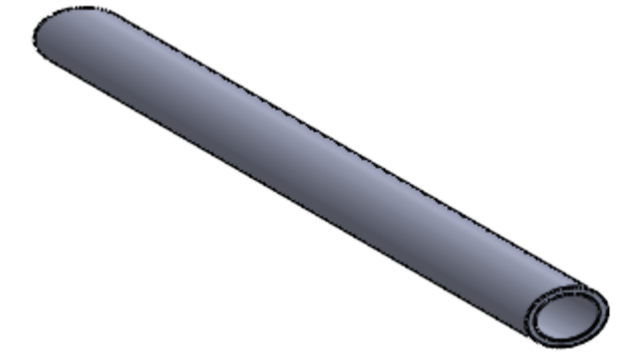
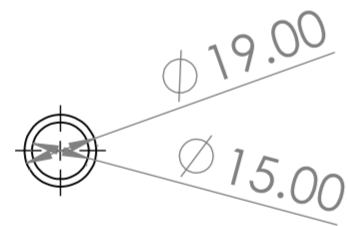

UNLESS OTHERWISE SPECIFIED: DIMENSIONS ARE IN MILLIMETERS				FINISH:		DEBURR AND BREAK SHARP EDGES		DO NOT SCALE DRAWING		REVISION
SURFACE FINISH:				TOLERANCES:		LINEAR:		ANGULAR:		TITLE:
DRAWN				NAME		SIGNATURE		DATE		16,18,19,20
CHK'D				NAME		SIGNATURE		DATE		
APPV'D				NAME		SIGNATURE		DATE		
MFG				NAME		SIGNATURE		DATE		
Q.A				NAME		SIGNATURE		DATE		
MATERIAL:				WEIGHT:		SCALE:1:2		SHEET 8 OF 13		DWG NO. 16,18,19,20
TITLE: Brake disk, upper pivot block support Control arm link1,2				A2						

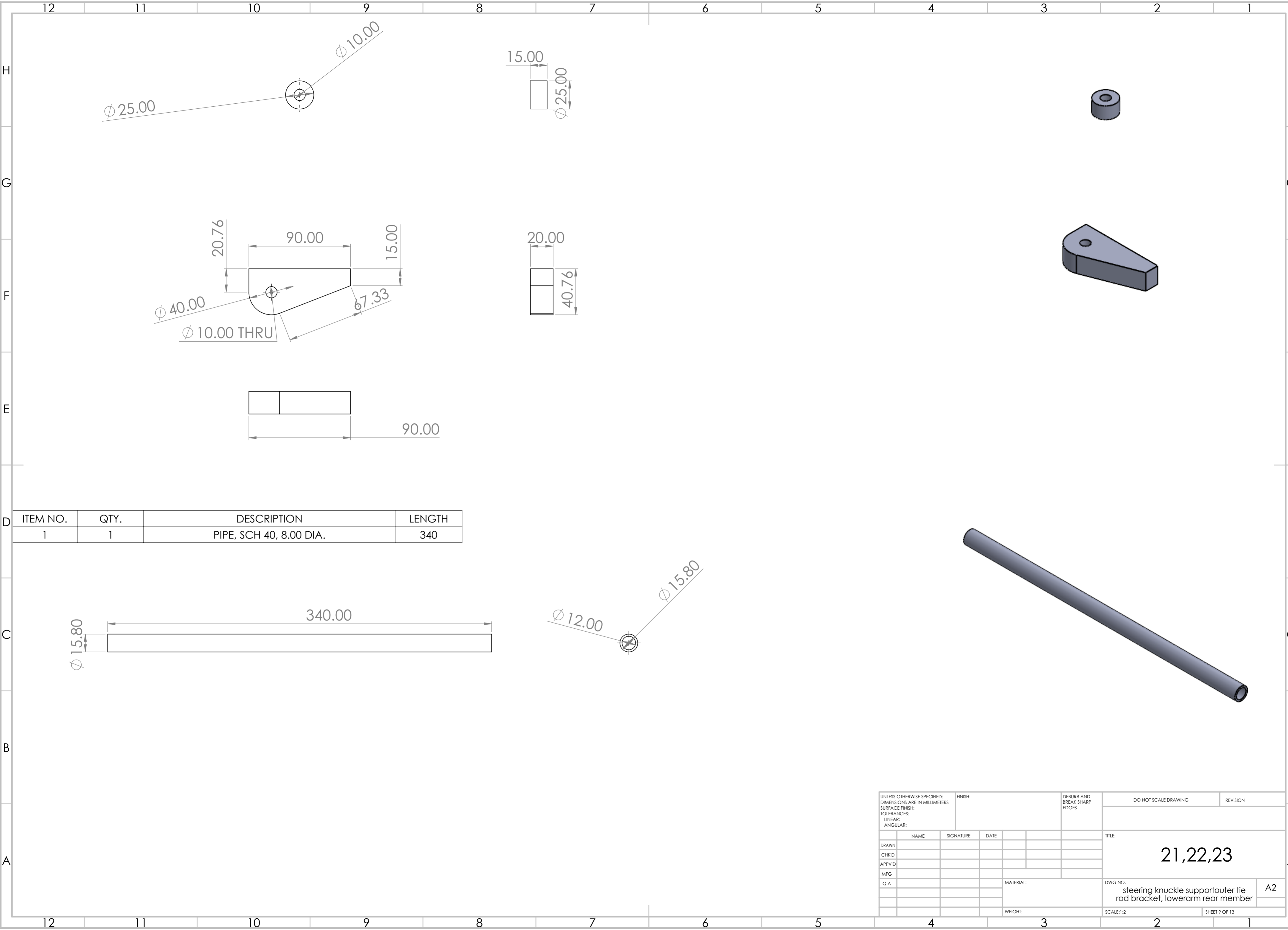

ITEM NO.	QTY.	DESCRIPTION	LENGTH
1	1	PIPE, SCH 40, 8.00 DIA.	340

UNLESS OTHERWISE SPECIFIED: DIMENSIONS ARE IN MILLIMETERS				FINISH:		DEBURR AND BREAK SHARP EDGES		DO NOT SCALE DRAWING		REVISION	
SURFACE FINISH:											
TOLERANCES:											
LINEAR:											
ANGULAR:											
DRAWN		NAME		SIGNATURE		DATE		TITLE:		21,22,23	
CHK'D											
APPV'D											
MFG											
Q.A								MATERIAL:		DWG NO. steering knuckle support outer tie rod bracket, lower arm rear member A2	
								WEIGHT:		SCALE:1:2 SHEET 9 OF 13	



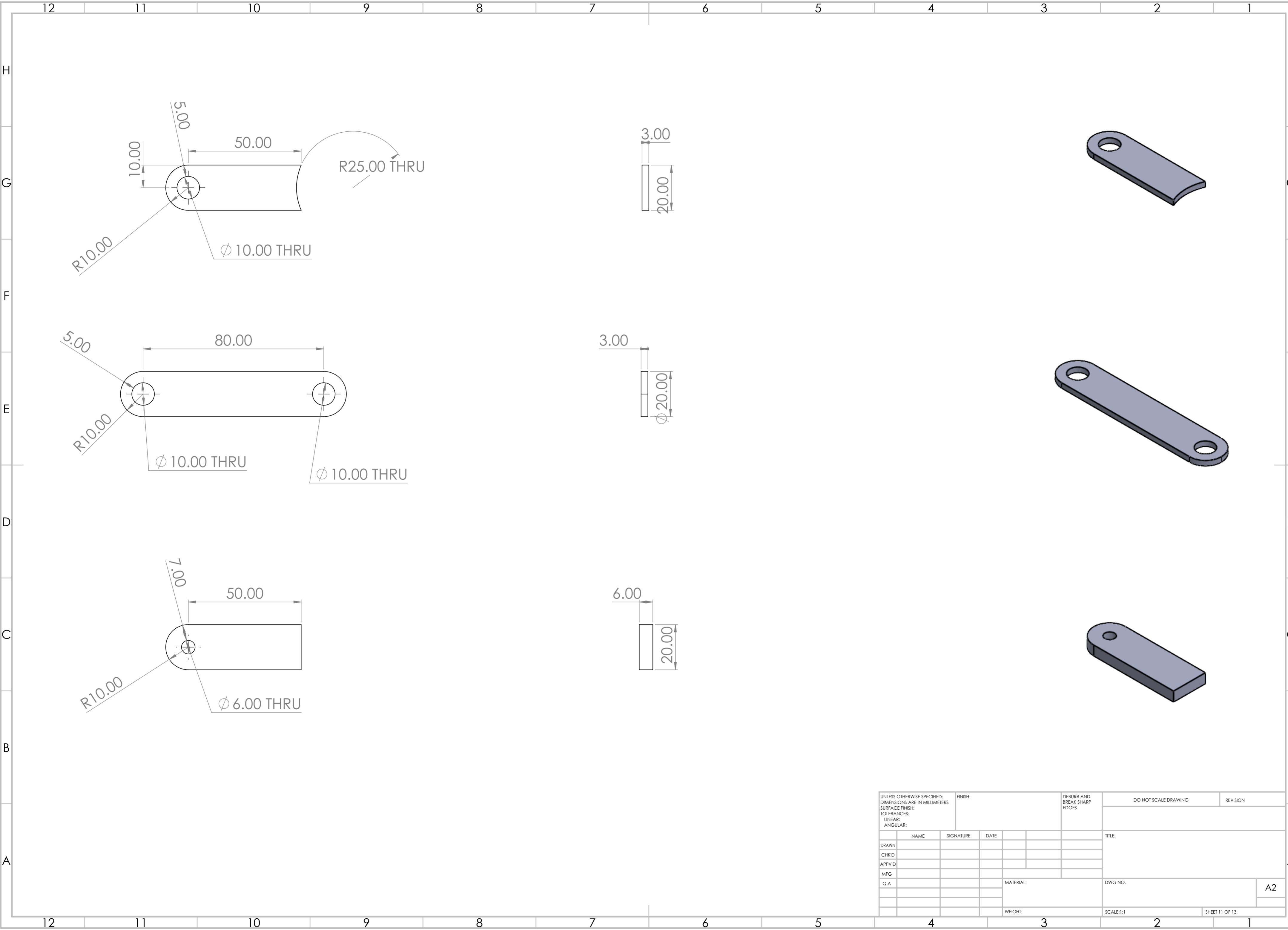

UNLESS OTHERWISE SPECIFIED: DIMENSIONS ARE IN MILLIMETERS				FINISH:		DEBURR AND BREAK SHARP EDGES		DO NOT SCALE DRAWING		REVISION	
SURFACE FINISH:											
TOLERANCES:											
LINEAR:											
ANGULAR:											
	NAME	SIGNATURE	DATE					TITLE:			
DRAWN											
CHK'D											
APPV'D											
MFG											
Q.A								MATERIAL:		DWG. NO.	
										A2	
								WEIGHT:		SCALE:1:1	
										SHEET 11 OF 13	



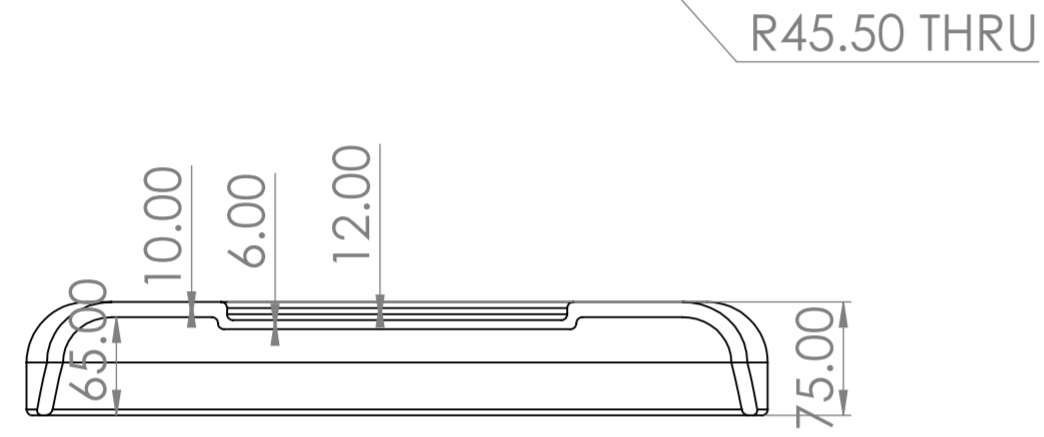
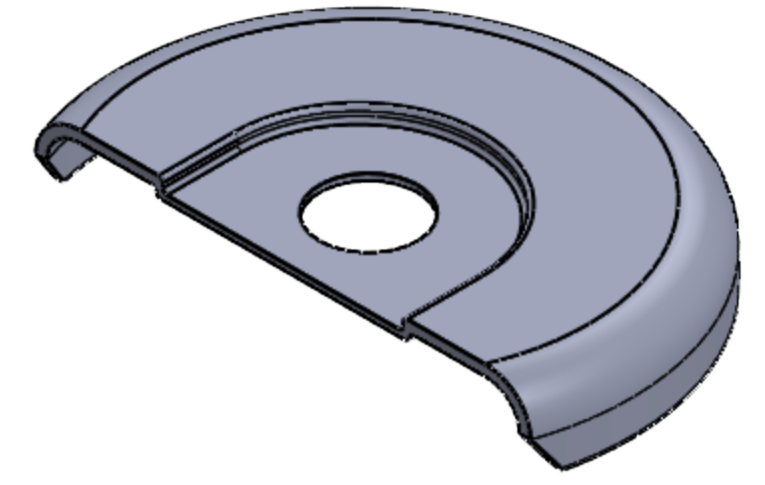
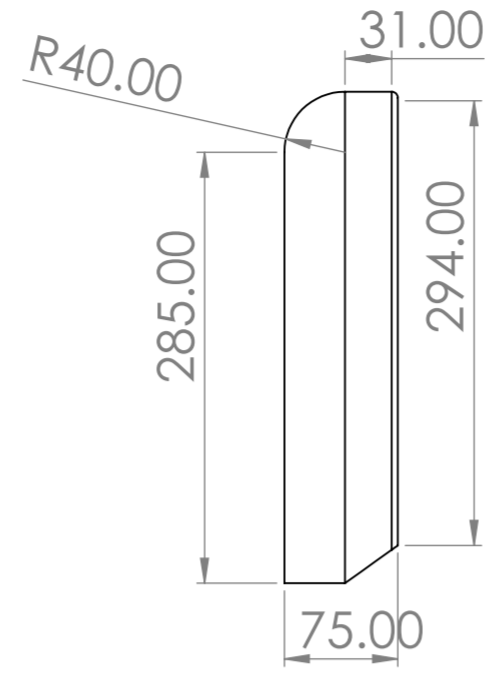
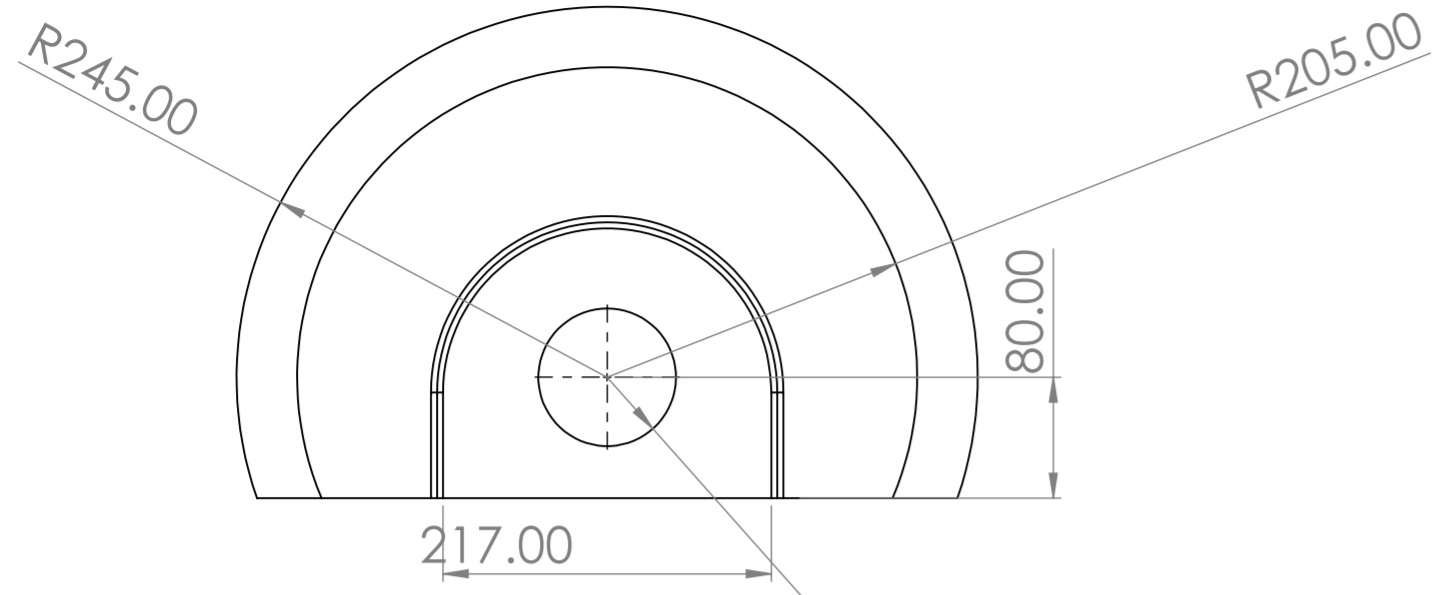

R45.50 THRU

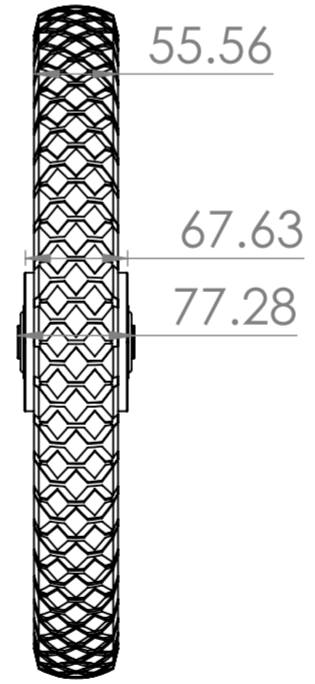
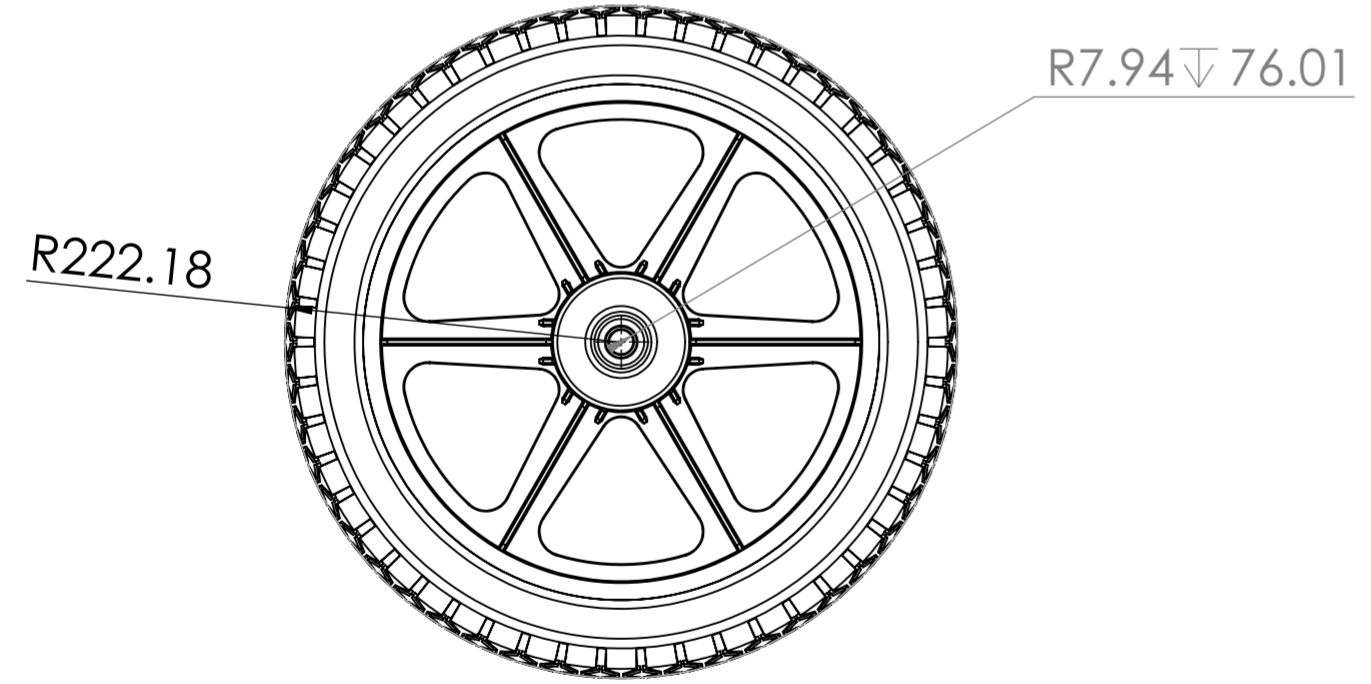

UNLESS OTHERWISE SPECIFIED: DIMENSIONS ARE IN MILLIMETERS				FINISH:		DEBURR AND BREAK SHARP EDGES		DO NOT SCALE DRAWING		REVISION	
TOLERANCES: LINEAR: ANGULAR:											
DRAWN		NAME		SIGNATURE		DATE		TITLE:			
CHK'D											
APPV'D											
MFG											
Q.A								MATERIAL:		DWG NO.	
								WEIGHT:		SCALE:1:5	
										SHEET 13 OF 13	
										A2	